

4

3

2

1

REVISIONS		
REV.	DESCRIPTION	DATE
1.0	INITIAL RELEASE	9/16/2024

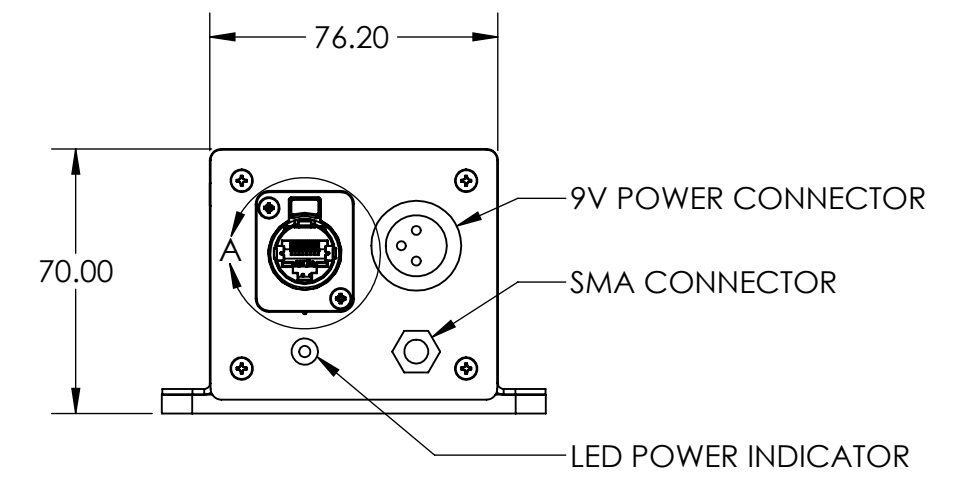
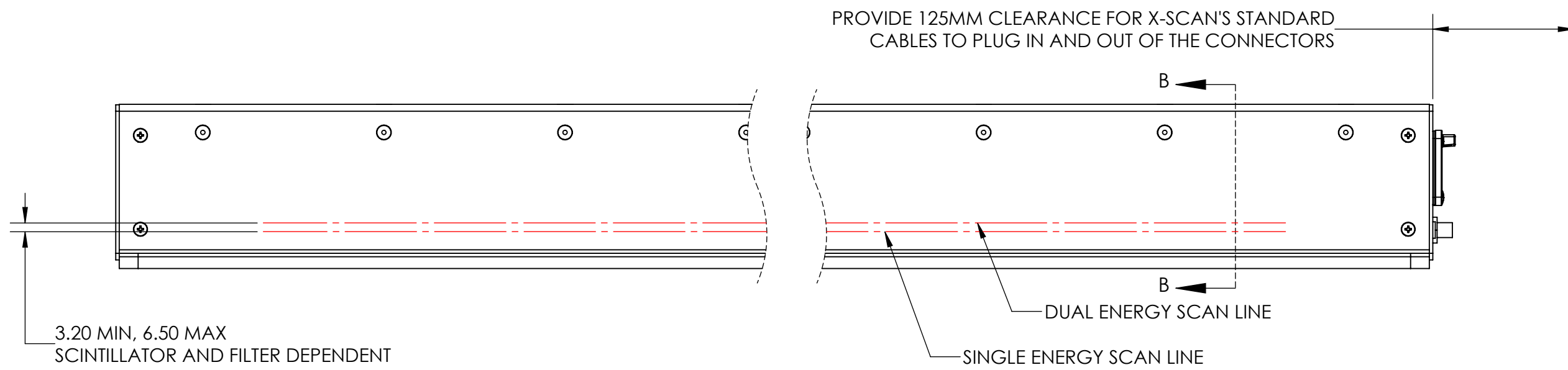
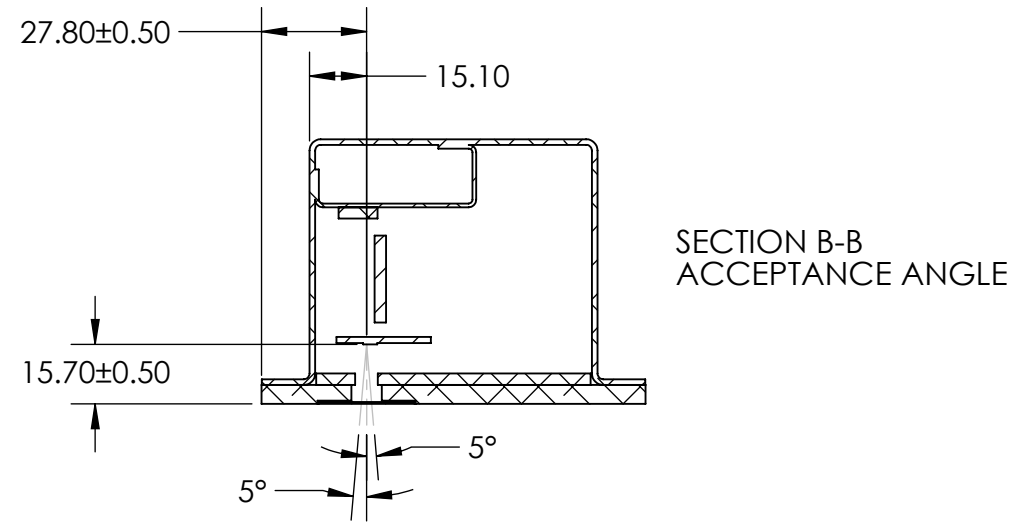

LENGTH CODE	012	014	016	018	020	022	024	026	028	030	032	034	036	038	040	042	044	046	048	050	052	054	056	058	060	062	064	066	068	070	072
SCAN LINE LENGTH	308	360	411	462	513	565	616	667	719	770	821	873	924	975	1026	1078	1129	1180	1232	1283	1334	1386	1437	1488	1539	1591	1642	1693	1745	1796	1847
BASE LENGTH	457	611	611	611	765	765	765	919	919	919	1073	1073	1073	1228	1228	1228	1382	1382	1382	1536	1536	1536	1690	1690	1690	1844	1844	1844	1999	1999	1999

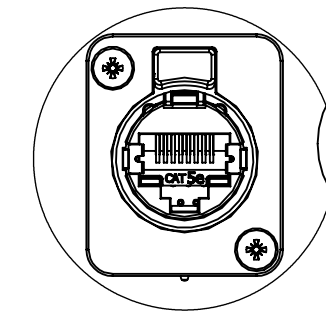

DETAIL A  
OPTION 1  
GX CONNECTOR  
RJ45, CAT5E

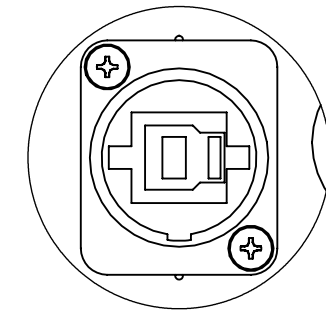

DETAIL A  
OPTION 2  
U CONNECTOR  
USB 3.0, TYPE B

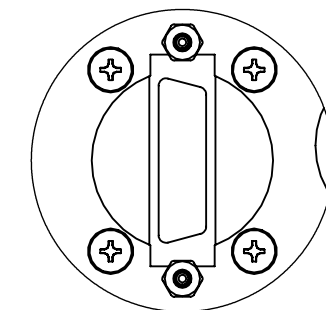

DETAIL A  
OPTION 3  
C CONNECTOR  
CAMERA LINK

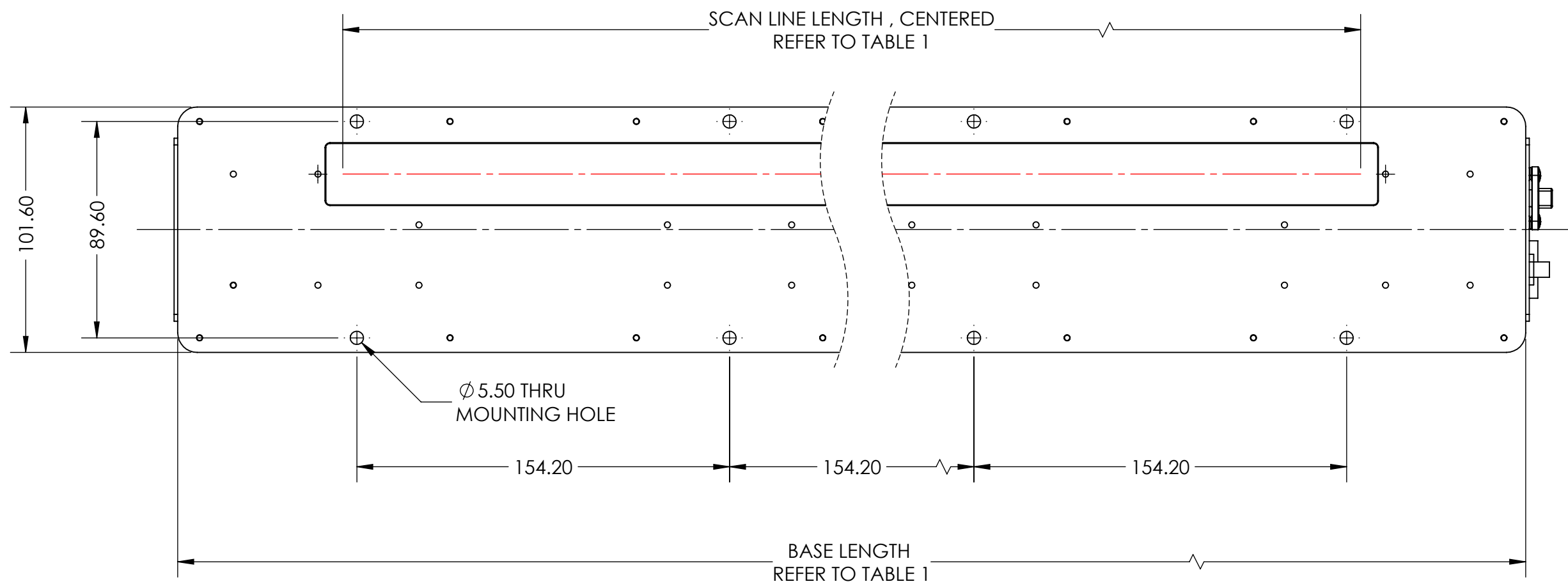

SCAN DIRECTION

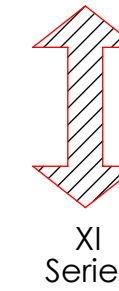

XI Series

CUSTOMER NAME	SIGNATURE	DATE

**PROPRIETARY AND CONFIDENTIAL**  
THE INFORMATION CONTAINED IN THIS DRAWING IS THE SOLE PROPERTY OF X-SCAN IMAGING CORPORATION. ANY REPRODUCTION IN PART OR AS A WHOLE WITHOUT THE WRITTEN PERMISSION OF X-SCAN IMAGING CORPORATION IS PROHIBITED.

UNLESS OTHERWISE SPECIFIED:		NAME	DATE
DIMENSIONS ARE IN MM	DRAWN	MM	09/16/24
TOLERANCES:	CHECKED		
ANGLES: ± 0.5 DEGREES	ENG APPR.		
NO PLACE DECIMAL: ± 0.5	MFG APPR.		
ONE PLACE DECIMAL: ± 0.2	Q.A.		
TWO PLACE DECIMAL: ± 0.1	COMMENTS:		
INTERPRET GEOMETRIC TOLERANCING PER: ANSI Y-14.5			
MATERIAL			
FINISH			
DO NOT SCALE DRAWING			

**X-SCAN IMAGING** 107 Bonaventura Drive  
San Jose, CA 95134

TITLE: **CMOS-SS DRAWING**

SIZE DWG. NO. REV  
**C FILE-004878 1.0**

SCALE: 1:2 WEIGHT: SHEET 1 OF 1

4

3

2

1