

4

3

2

1

REVISIONS		
REV.	DESCRIPTION	DATE
1.5	INITIAL RELEASE	08/13/2024
2.0	SCAN LINE DISTANCE FROM BASE CHANGED FROM 14.70 TO 15.70mm. CHANGED RJ45 CONNECTOR. ROTATED POWER CONNECTOR BY 90°.	9/16/2024

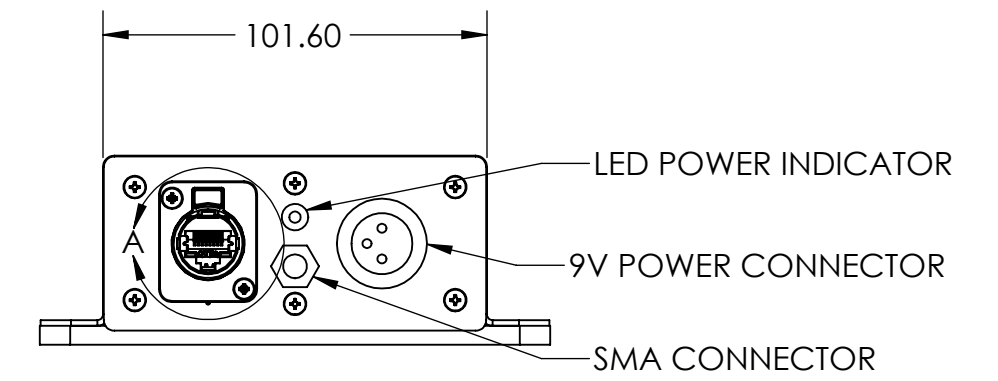
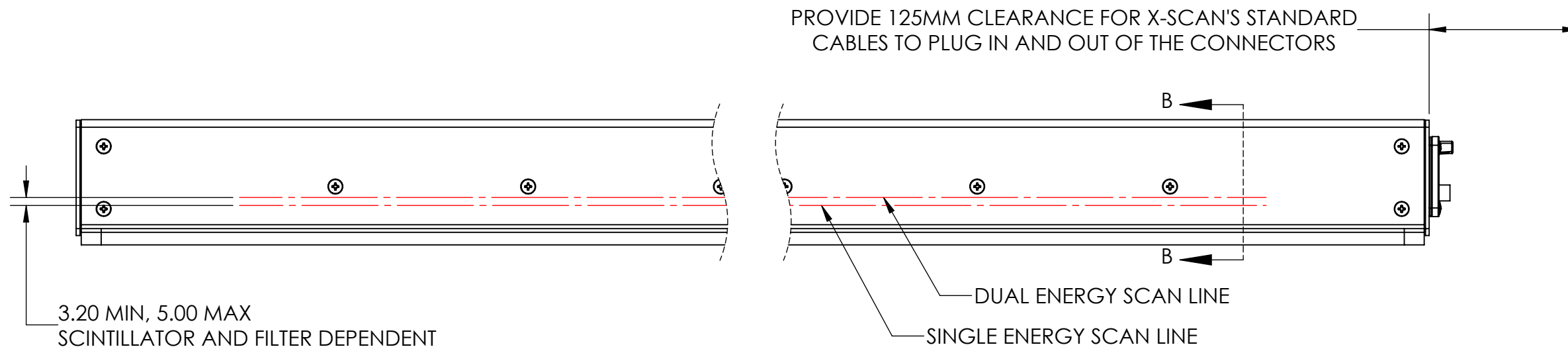
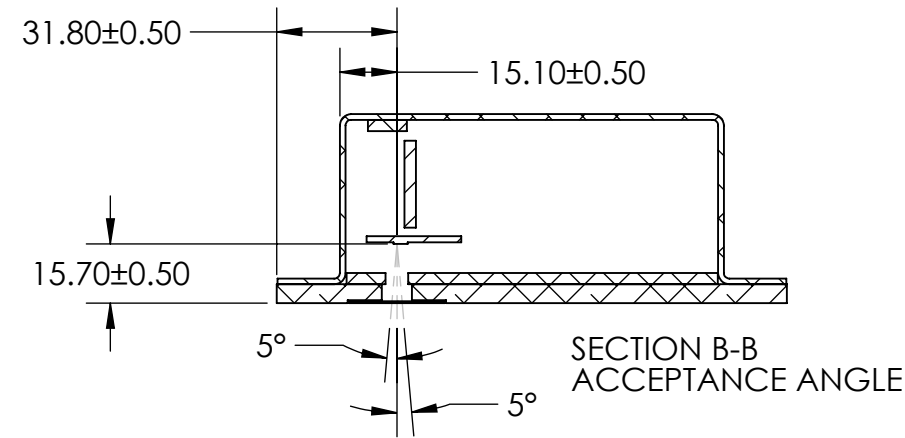
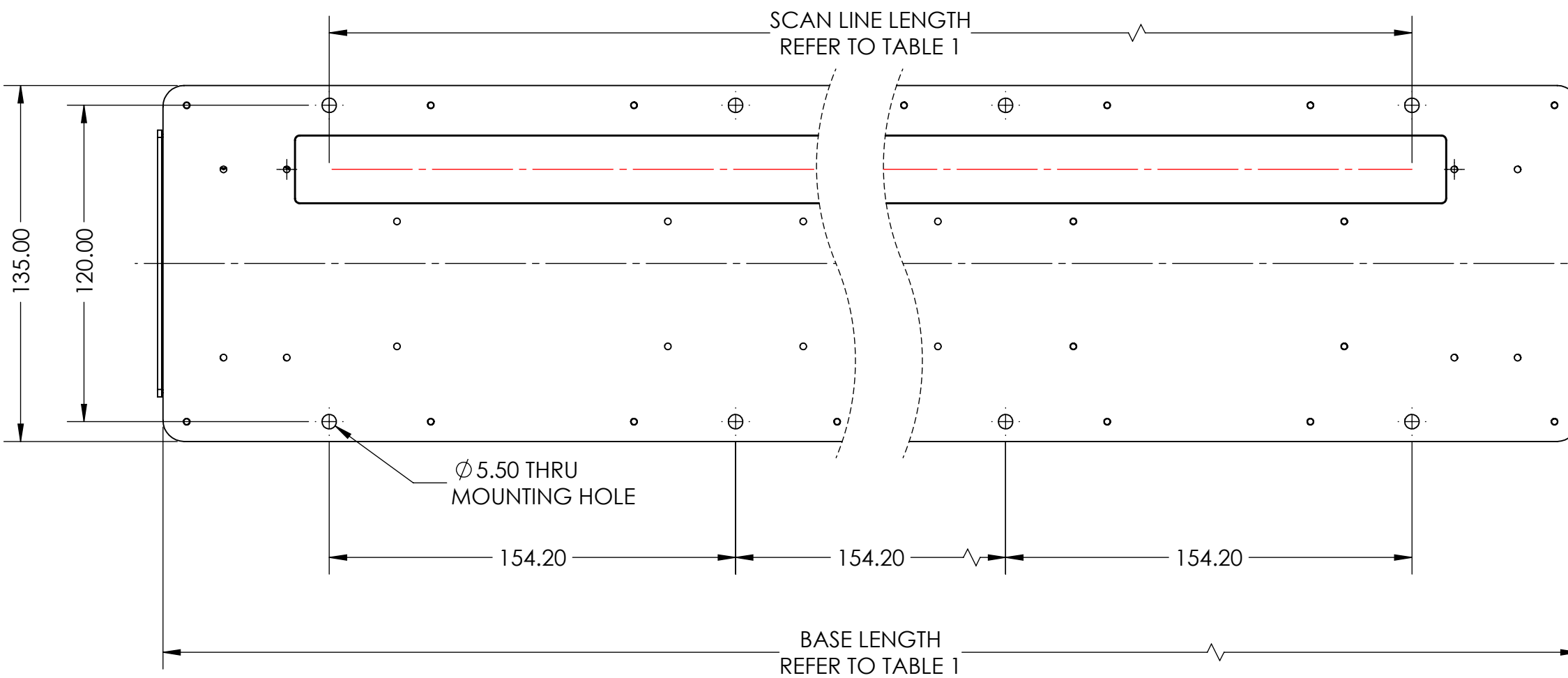
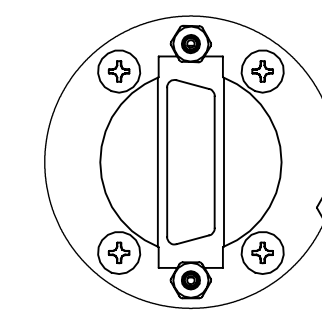
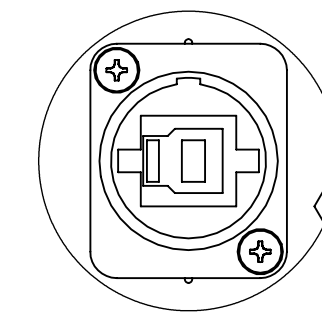
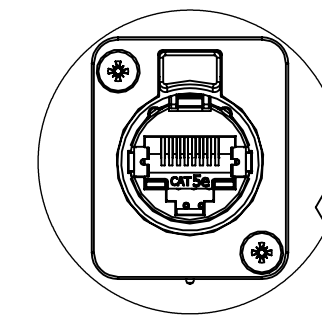

TABLE 1

LENGTH CODE	012	014	016	018	020	022	024	026	028	030	032	034	036	038	040	042	044	046	048	050	052	054	056	058	060	062	064	066	068	070	072
SCAN LINE LENGTH	308	360	411	462	513	565	616	667	719	770	821	873	924	975	1026	1078	1129	1180	1232	1283	1334	1386	1437	1488	1539	1591	1642	1693	1745	1796	1847
BASE LENGTH	435	589	589	589	743	743	743	898	898	898	1052	1052	1052	1206	1206	1360	1360	1360	1514	1514	1514	1669	1669	1669	1823	1823	1823	1977	1977	1977	



UNLESS OTHERWISE SPECIFIED:		NAME	DATE	X-SCAN IMAGING 107 Bonaventura Drive San Jose, CA 95134
DIMENSIONS ARE IN MM TOLERANCES: ANGLES: ± 0.5 DEGREES NO PLACE DECIMAL: ± 0.5 ONE PLACE DECIMAL: ± 0.2 TWO PLACE DECIMAL: ± 0.1		MM	09/16/24	
DRAWN		CHECKED	ENG APPR.	TITLE: CMOS-SR DRAWING
MFG APPR.		Q.A.	COMMENTS:	
INTERPRET GEOMETRIC TOLERANCING PER: ANSI Y-14.5		MATERIAL		SIZE DWG. NO. REV C FILE-004662 2.0
FINISH		DO NOT SCALE DRAWING		SCALE: 1:2 WEIGHT: SHEET 1 OF 1

CUSTOMER NAME	SIGNATURE	DATE

4

3

2

1